



# Rexious

## G-type

LONG TAB MIS SPINAL SYSTEM





# Table of Contents

<b>1. Implant Overview</b>	<b>1</b>
<b>2. Surgical Technique Guide</b>	<b>2</b>
<b>3. Instrument Overview</b>	<b>18</b>

# 1. Implant Overview

## Rexious G-type Polyaxial Screws

Anodized color code for identifying screw diameter easily.

Screw Size / Color	5.5mm / Green 						6.5mm / Gold 						7.5mm / Fuchsia 					
Available Lengths (mm)	35	40	45	50	55	60	35	40	45	50	55	60	35	40	45	50	55	60
Qty	4	4	4	4	4	2	6	8	8	8	6	2	6	6	6	6	6	6

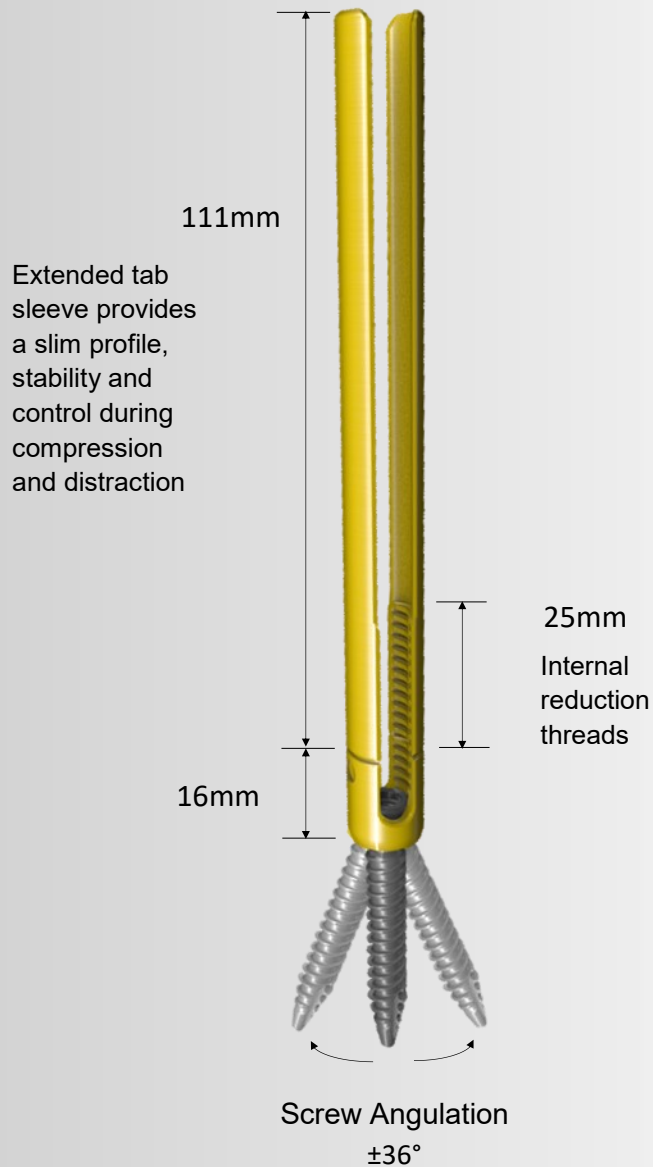

### Rexious G-type Set Screw



- \* Set Screw - 5.0 Hex
- \* Outer diameter 9.8mm
- \* Height 5.3mm

### Rexious G-type Curved Rod Ø 5.5mm



- \* Titanium alloy (Ti-6Al-4V)
- \* Bullet tip end for easy insertion
- \* Length
  - 35 - 70 (5mm incr)
  - 80 - 140 (10mm incr)

## 2. Surgical Technique

### STEP 1. Patient Positioning

Patient is placed prone on a reversed surgical bed with a radiolucent Wilson Frame, taking care to preserve the sagittal alignment of the spine. All pressure points are well padded, and baseline neurophysiological monitoring is performed. Skin of the patient is prepped and draped in the standard fashion. Lateral fluoroscopy is utilized to localize a level of pathology.

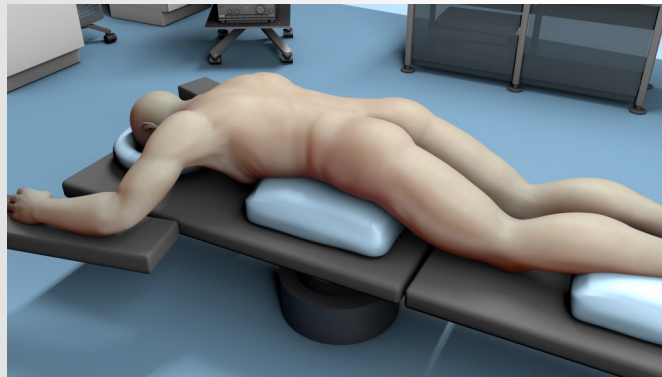

Figure 1

### STEP 2. Skin Marking

Using A/P imaging, place a **K-Wire** across the mid-line of the targeted pedicles, and draw a reference line. For pedicle screws, the entry point is approximately 4 cm off mid-line with a more lateral trajectory. The incision is approximately 1.5 cm in length to match the diameter of the screw body.

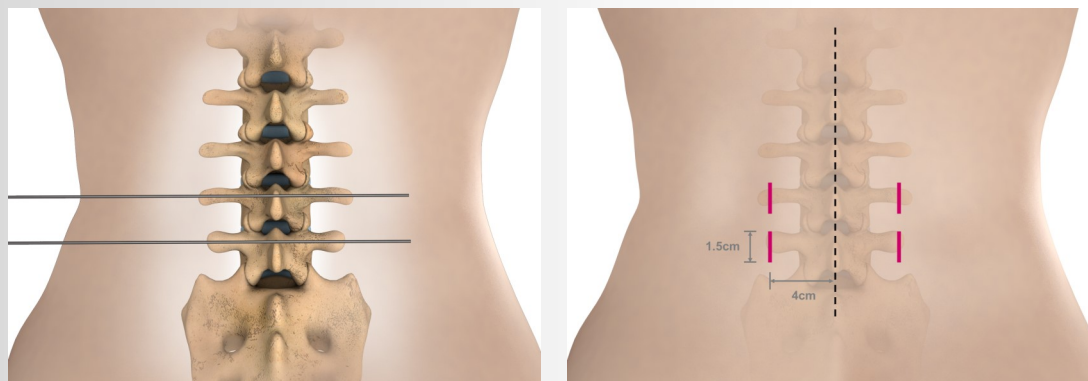

Figure 2

## 2. Surgical Technique

### STEP 3. K-Wire Insertion

Insert a **VP Needle** through the skin incision to the intersection of the facet and transverse process. Confirm that the VP Needle is in the appropriate pedicle starting point by using both A/P and lateral images. Once it is confirmed that the Needle is on the starting point (Figure 3) by both A/P and lateral views, advance the VP Needle to the desired depth within the vertebral body by using the Hammer (Figure 4).

\*Note: Each time the Needle is advanced, fluoroscopic images should be obtained.



Figure 3

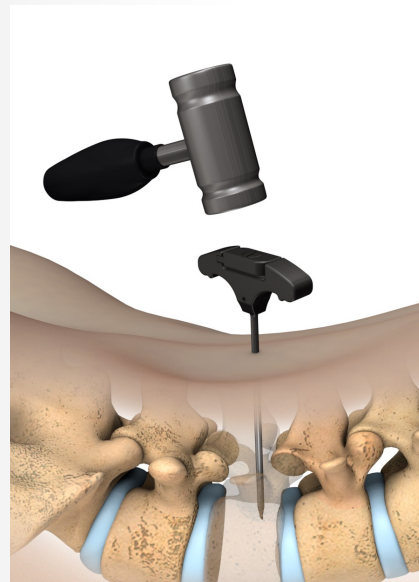

Figure 4

As the Needle advances through the pedicle, it should approach the medial wall of the pedicle on the A/P images and should approach the base of the pedicle on the lateral images. When the Needle reaches the medial wall on the A/P image, verification must be performed in the lateral image to ensure that the Needle is past the base of the pedicle and starting to enter the vertebral body.

## 2. Surgical Technique

### STEP 3. K-Wire Insertion (Cont'd)

The inner stylet is removed (Figure 5), and this allows the K-Wire to be inserted (Figure 6). The K-Wire Guide Tube can be used to prevent the K-Wire from bending or moving during insertion. Once the K-Wire is inserted, remove the K-Wire Guide Tube, if used, and the outer shaft of the Needle.

\*Note: Hold the K-Wire in position when removing the outer shaft of the Needle.

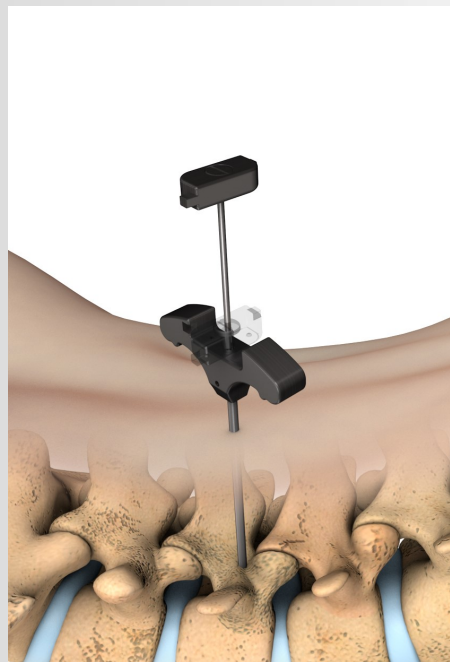

Figure 5

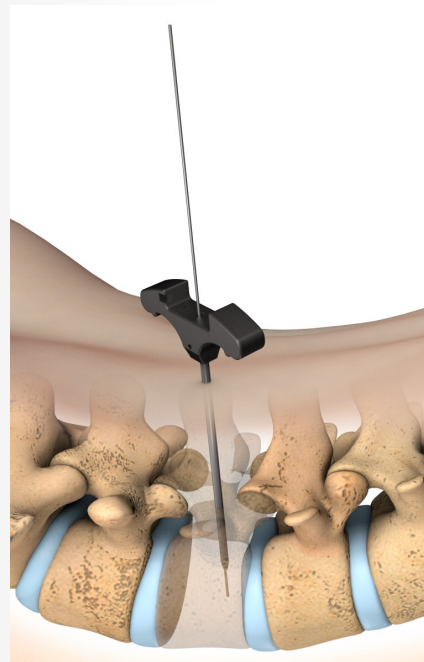

Figure 6

## 2. Surgical Technique

### STEP 4. Tissue Dilation

In preparation for tapping the pedicle, start to place **Dilator 1** over the K-wire and advance through the muscle to the pedicle. This is followed by **Dilator 2** and Final Dilator (Figure 8). To address surgeon needs, 3 different types of **Final Dilators** are provided that allow for different types of engagement with the bone.

(Final Dilators 4 and 5 are optional.)

Dilator 1: DILATOR, ID 1.8 x OD 10mm  
Dilator 2: DILATOR, ID 10 x OD 14mm  
Final Dilator 3: DILATOR, ID 14 x OD 16mm  
Final Dilator 4: DILATOR, FULL SPIKE - ID 14 x OD 16mm  
Final Dilator 5: DILATOR, ANGLED SPIKE - ID 14 x OD 16mm



Figure 7

Remove Dilators 1 and 2 after the Final Dilator is advanced (Figure 8).

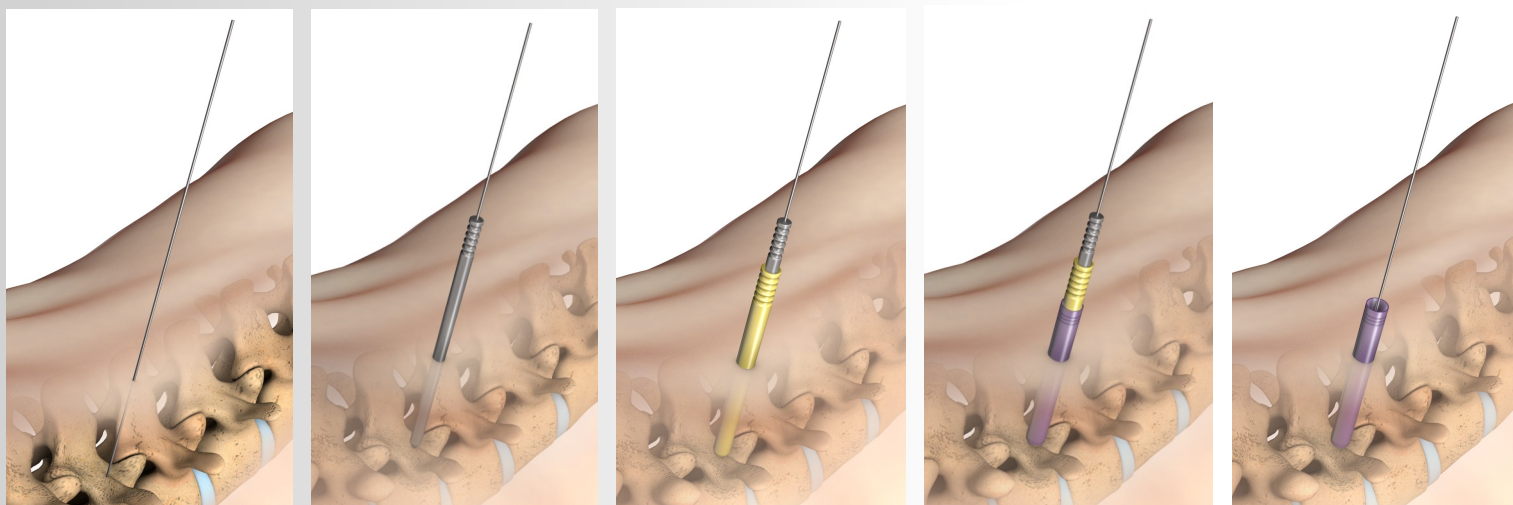

Figure 8



## 2. Surgical Technique

### STEP 5. Pedicle Preparation

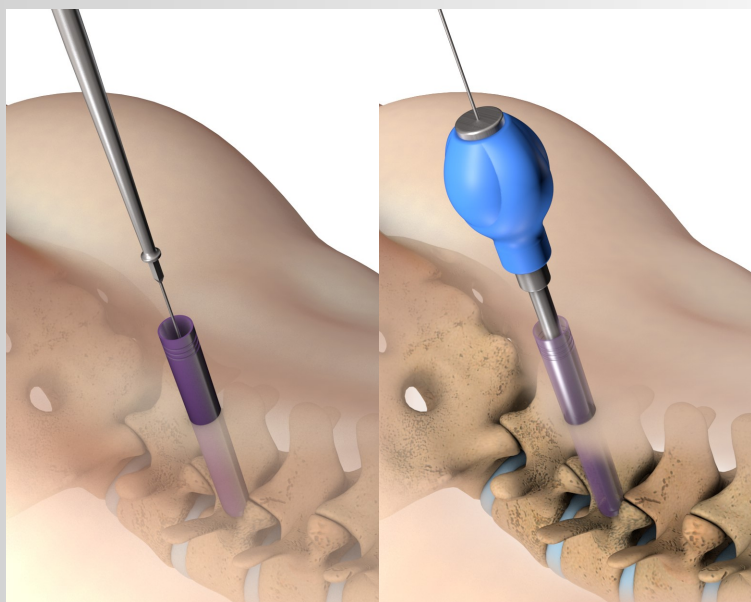

Figure 9

With the desired Final Dilator in place, prepare the pedicle for screw insertion by placing the **Cannulated Awl** over the K-Wire and insert into the pedicle with a twisting motion to create an entry pathway for the Tap or screw (Figure 9). Hold the K-Wire in position during removal of the Awl.

The **Cannulated Taps**, with either **Ratcheting or T-handle**, are used to further prepare the screw pathway (Figure 10). Take a lateral x-ray to ensure the tap is collinear with the Guide Wire. The Taps are laser marked with lines at 5mm increments to help indicate the depth of the Tap within the pedicle as well as to help determine proper screw length (Figure 11). After pedicle has been prepared, remove the entire assembly of the tap and the outer dilator together. Hold the K-Wire in position during removal of Tap.

\*Note: Drill is optional, surgeon's preference.

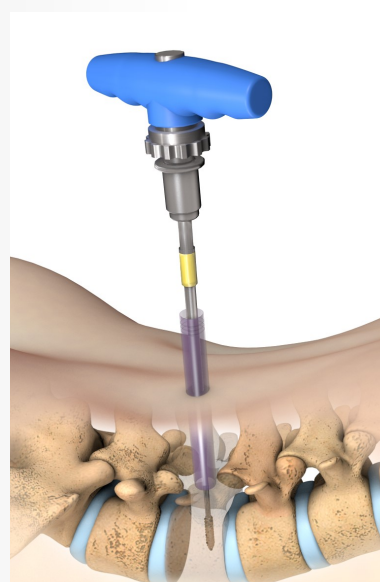

Figure 10



Figure 11

## 2. Surgical Technique

### STEP 6. Screw Insertion

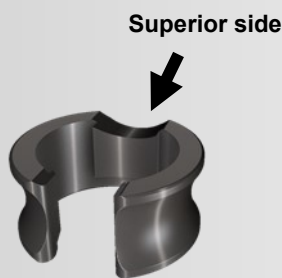

Figure 12

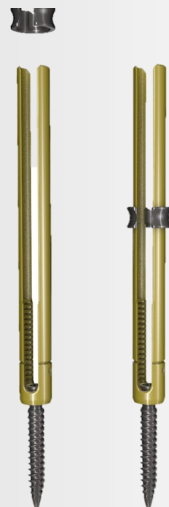

Figure 13

#### A. Select a proper screw implant

With the pedicle pathway prepared and the appropriate screw diameter and length determined, the screw is prepared for insertion. Orient the **Ring** in the desired position (Figure 13).

\*Note: Before engaging the Ring on the extended tab, groove (superior side) must face the open end of the tab (Figure 12).

#### B. Load the screw on the Cannulated Screw Driver

- 1) Hold the Screw by the threaded portion and engage the **inner shaft of Cannulated Screw Driver** into the saddle of the screw head (Figure 14).
- 2) Fully seat the Cannulated Screw Driver into the screw head and engage the hex of the screw. Turn the **knob** of the Cannulated Screw Driver clockwise until the threads of the shaft are fully engaged with the threads of the screw head (Figure 14).
- 3) Slide the locking part forward into the Cannulated Screw Driver to lock the Screw to the Cannulated Screw Driver (Figure 15). When it is locked completely, the **locking button** will pop-up (Figure 16).
- 4) Connect the Ratcheting T-handle to the assembly



Figure 14

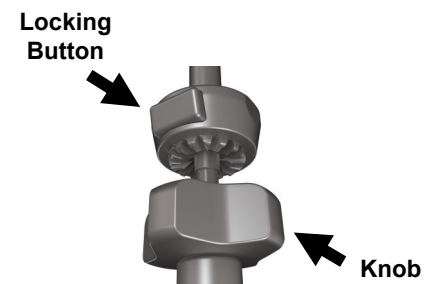

Figure 15

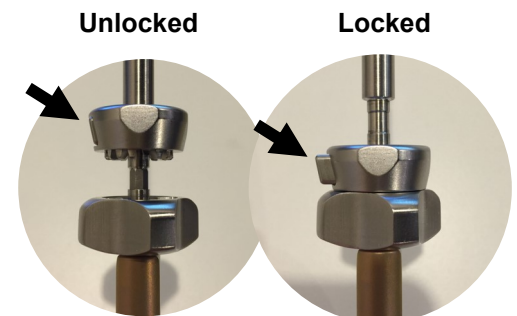

Figure 16

## 2. Surgical Technique

### STEP 6. Screw Insertion (Cont'd)

#### C. Screw Insertion

Place the Screw and Cannulated Screw Driver over the K-Wire and insert into the pedicle (Figure 17 A). Remove the K-Wire when the tip of the screw reaches the end of the pedicle to prevent it from advancing. Take caution not to insert the screw too far into the bone, thereby limiting its poly-axial capabilities making it more difficult to pass the rod during subsequent procedural steps (Figure 18).

\*Note: Screw insertion without Ring is surgeon's preference (Figure 17 B).

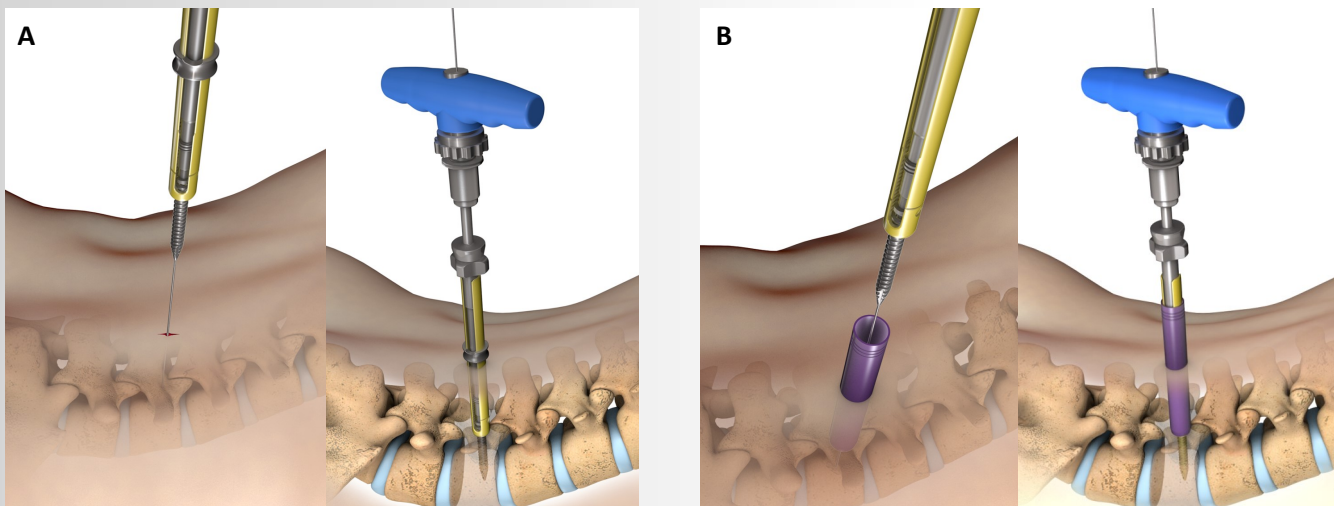

Figure 17 (A: Extended tab with Ring, B: Extended tab without Ring)

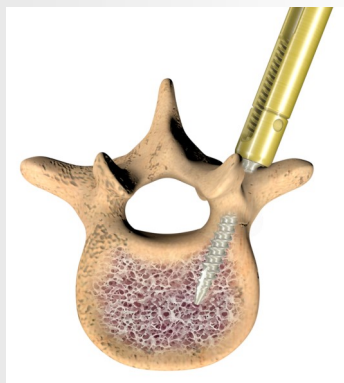

Figure 18

## 2. Surgical Technique

### STEP 7. Cannulated Screw Driver Disengagement

Once the screw is placed in the proper position:

- A. Press the **locking button** and pull out the inner shaft of the Screw Driver.
- B. Turn the Knob of the Screw Driver counterclockwise to disengage the threads of the Screw Driver from the threads of the screw head.
- C. Pull upward on the Cannulated Screw Driver while ensuring the Ring stays on (Figure 19).

\*Note: The orientation and placement of the Ring can be changed after removal of the Cannulated Screw Driver.

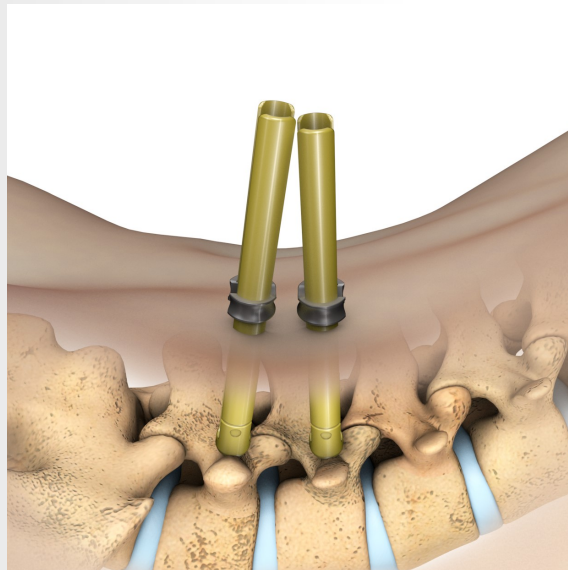
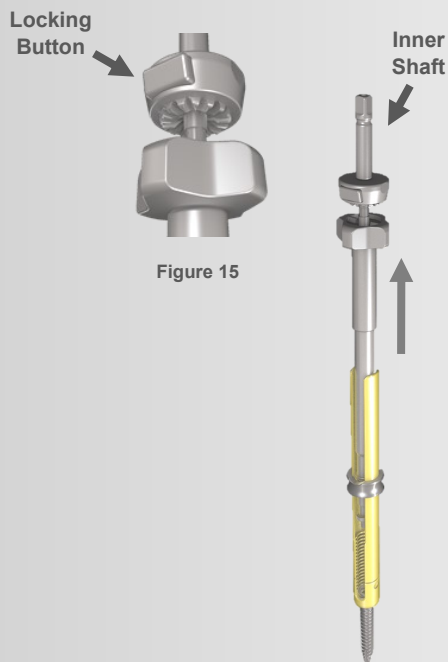

**\*\*Note: Repeat steps 3 to 7 for all targeted pedicles and pedicle screws.**

## 2. Surgical Technique

### STEP 8. Head Alignment and Screw Adjustment

The screw tulip position may be adjusted as needed using the **Head Alignment**, and the screw either can be loosened or tightened depending on how far the screw needs to be adjusted using the **Screw Adjuster**. Imaging should be used to confirm desired placement of screw.

\*Note: Screw Adjuster can be used as a screw remover.

### STEP 9. Rod Length Measurement

Place the ball tips of the **Caliper** down until it reaches the end of the screw heads. Verify the ball tips are fully seated in the screw heads using fluoroscopic imaging, or the extended tab length laser markings on the indicator arms. Read the rod length indicated on the appropriate system scale (Figure 20).

\*Note: The ball tip is optimized to determine the Rod length from 1 to 2 levels.

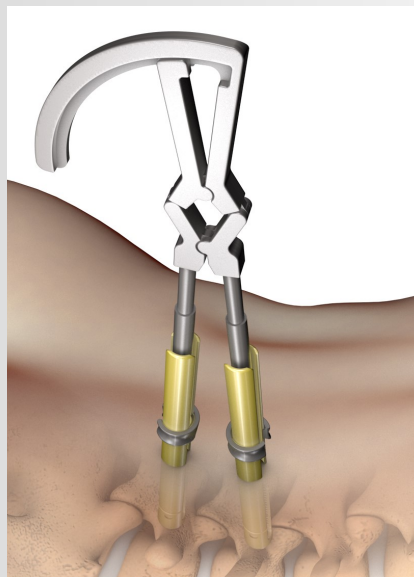

Figure 20

## 2. Surgical Technique

### STEP 10. Rod Selection and Contouring

The Rexious G-type offers a comprehensive selection of MIS Rods. The Rexious G-type Screw can accept 5.5mm rod diameter. The rods are offered in titanium alloy, in Pre-contoured configurations. The **Rod Bender** is used to contour the rod as needed.

### STEP 11. Rod Inserter Assembly

- A. Place the end of the rod into the opening on the distal end of the **Rod Inserter**. Lock the rod into position by twisting the knob (Figure 21) on the Rod Inserter Shaft clockwise until fully engaged with the rod. Check that the connection is rigid.
- B. The Rod Inserter should be disassembled for cleaning. To disassemble, turn the Rod Inserter Shaft counterclockwise. The threaded portion is released by pulling the Rod Inserter Shaft.
- C. The **Rod Inserter Driver** is used to reduce the rod as needed.

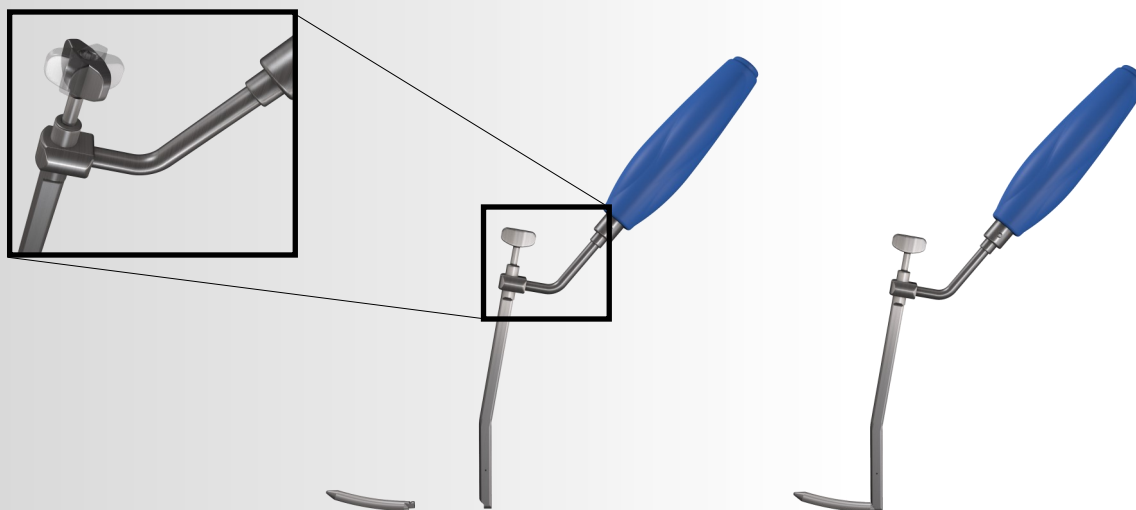

Figure 21



## 2. Surgical Technique

### STEP 12. Rod Insertion

- A. Insert the rod percutaneously from either the most cephalad or caudal screw through the extended tabs. Guide the rod through each pair of extended tabs.
- B. The opening of the Ring at the most cephalad screw should be oriented in the cephalad direction and the opening of the Ring at the most caudal screw should be oriented in the caudal direction. The rod is to be inserted from the open side of the Ring.
- C. Ensure that the rod overhangs the last screw head to allow for secure fixation. Also, the hex end of the rod should not be within the first screw head.
- D. The Rod Inserter Driver can be used to reduce the rod, if needed.
- E. The positioning of the rod between the extended tabs can be visualized, by fluoroscopic imaging.

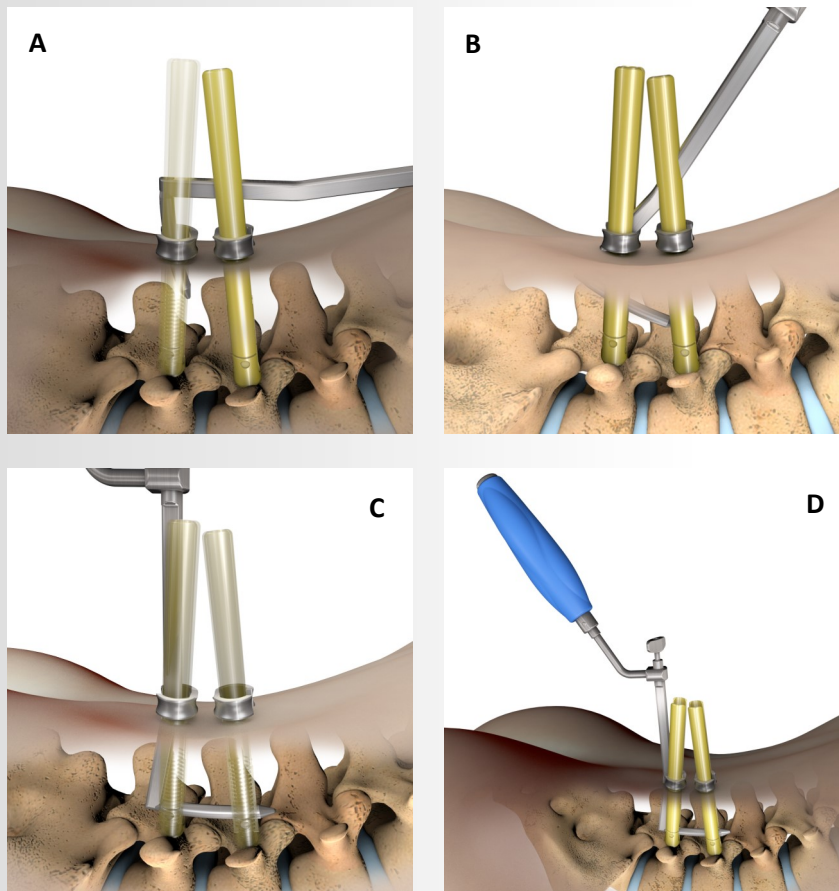

Figure 22

## 2. Surgical Technique

### STEP 13. Set Screw Insertion

- A. Load the Set Screw onto the tip of the self-retaining **Set Screw Driver Guide** by engaging the hex (Figure 23).
- B. Set Screw and Set Screw Driver Guide will help maintain the open position of the extended tabs. Thread the Set Screw, in a clockwise rotation, through the reduction threads of the extended tabs and into the Screw head (Repeat for other screws).
- C. The Set Screw Driver Guide is only intended to be used for provisional tightening (not with Torque Wrench Driver), before final adjustment is made.

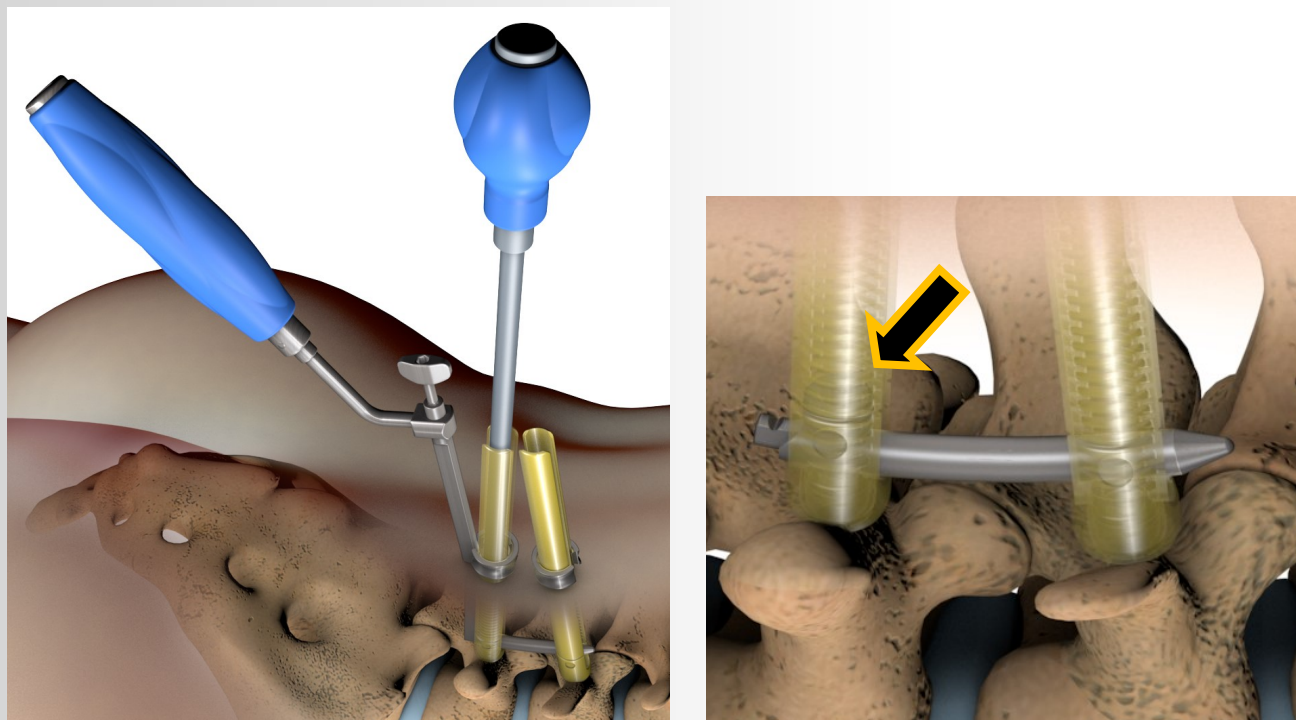

Figure 23



## 2. Surgical Technique

### STEP 14. Compression and Distraction

The Ring must be removed prior to using the Support Tower.

- A. Insert the **Support Tower** and assure it is fully seated. This can be verified when the extended tab ends are seen in the biggest hole of the Support Tower (Figure 24).
- B. Position **MIS Connector** with lock/release button facing up over Support Towers. Slide the lock button to release the lock of MIS Connector. Align the holes of Support Towers, and close MIS Connector to lock Support Towers into position (Figure 25).

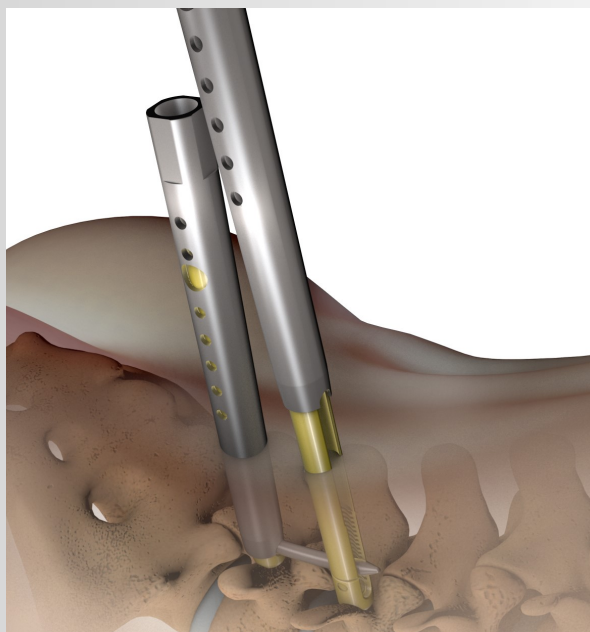

Figure 24

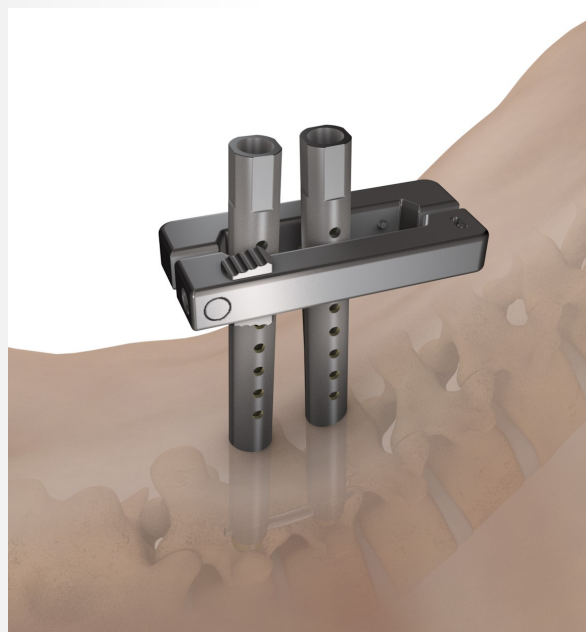

Figure 25

## 2. Surgical Technique

### STEP 14. Compression and Distraction (Cont'd)

#### Compression

To compress, insert the Compressor into the eyelets of the Support Tower. It must be located **lower** than the MIS Connector.



Figure 26

#### Distraction

To distract, insert the Compressor into the eyelets of the Support Tower. It must be located **higher** than the MIS Connector.



Figure 27

## 2. Surgical Technique

### STEP 15. Final Tightening of the Construct

A. The top of the Support Towers interface with the **Anti-torque A type** (Figure 28, left). The Anti-torque A type can be used, if needed, to secure the Support Towers in fully seated position by applying downward force on the Support Towers during the application of compression or distraction.

\*Individual tightening: A type (1-level surgery), align tightening: C type (2-level surgery)

B. The **Anti-torque C type** (Figure 28, right) can be used for final tightening of the Set Screws with the Multi-level Compressor/Distractor in place. The **Torque Wrench** must be used for final tightening of the construct.

C. Once the final necessary adjustment has been performed for the construct, the final tightening of the Set Screws is performed using the Anti-torque A or C type and the Axial Torque Set Screw.

D. Turn the handle of the Torque Wrench clockwise to achieve the 12Nm of torque required to secure the implant construct until an audible click is heard.

E. Repeat for remaining screws.

F. Once the necessary compression or distraction is applied and secured by the set screws, the MIS Connector assembly can be released from the Support Tower and removed.

G. The Support Tower can then be removed from the extended tabs.

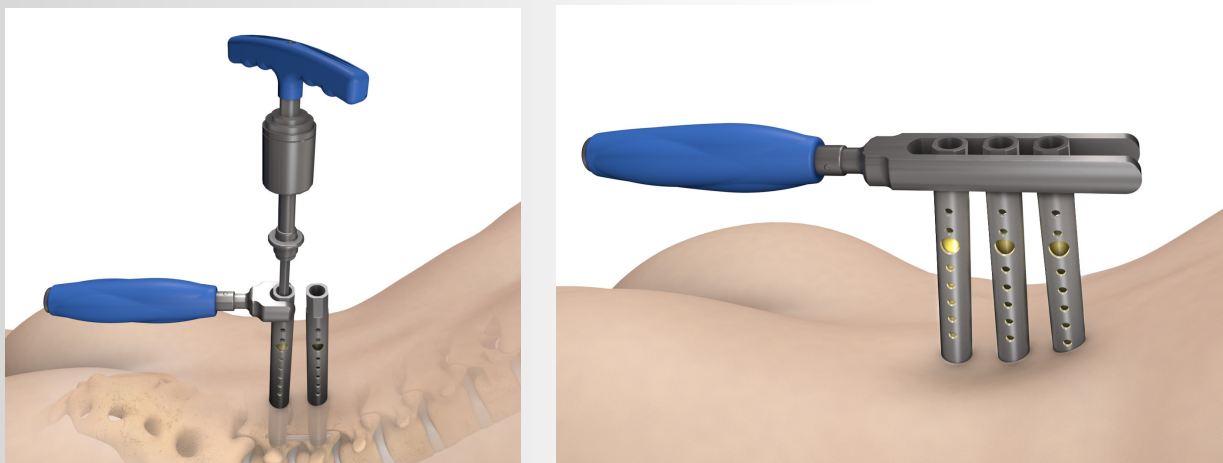

Figure 28 (Left: A type, Right: C-type)

## 2. Surgical Technique

### STEP 16. Extended Tab Removal

Perform a final verification of the Screw and Rod positioning using fluoroscopy.

- A. Once the construct is finally tightened, the extended tabs need to be removed. Slide the **Sleeve Cutter** up to the Set Screw (Figure 29).
- B. Apply a force In the direction of the arrow (medial and lateral direction), to break the extended tab off of the Screw head. The Sleeve Cutter will retain the extended tab within the instrument.
- C. Repeat for the remaining extended tabs to obtain the final construct (Figure 30).

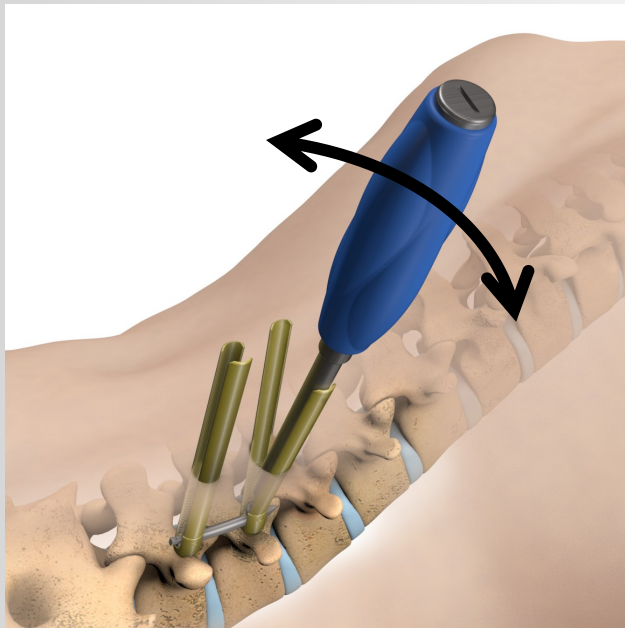

Figure 29

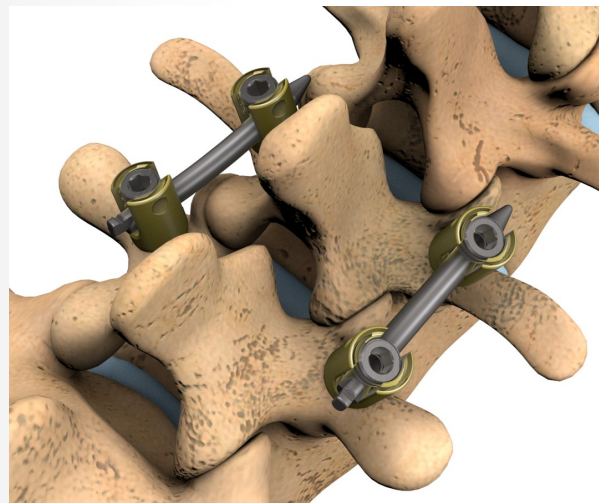



Figure 30











## 3. Instrument Overview

Part #	Description	Image
RG.IN.0056 (0055)	VP Needle Single (Triple)	
LT.IN.0020	K-Wire (Trocar Tip)	
LT.IN.0021	K-Wire Holder	
RG.IN.0025	Dilator 1	
RG.IN.0026	Dilator 2	
RG.IN.0027	Final Dilator 3	
RG.IN.0028	Final Dilator 4 (Spike)	
RG.IN.0029	Final Dilator 5 (Angled, Spike)	
SI.MI.0120	Awl	
RG.IN.0041	Tap 5.5mm	
RG.IN.0042	Tap 6.5mm	
RG.IN.0043	Tap 7.5mm	

## 3. Instrument Overview

Part #	Description	Image
RG.IN.0033	Drill 3.4mm	
RG.IN.0034	Drill 4.2mm	
RG.IN.0035	Drill 5.0mm	
RG.IN.0046	T-Handle	
RG.IN.0049	T-Handle Ratchet, 1/4" Square	
RG.IN.0001	Ring	
RG.IN.0019	Cannulated Screw Driver	
OSM0079	Head Alignment	
OSM0078	Screw Adjuster	
LT.IN.0031	Caliper	
OSM0080	Rod Bender	
RG.IN.0010	Rod Inserter	

## 3. Instrument Overview

Part #	Description	Image
RG.IN.0011	Rod Inserter Driver	
OSM00C0	Set Screw Driver Guide	
RG.IN.0003	Support Tower	
RG.IN.0009	Compressor (Distractor)	
RG.IN.0005	MIS Connector	
RG.IN.0050	T-Handle Torque Wrench, 1/4" Square 12N	
RG.IN.0024	Set Screw Driver	
RG.IN.0006	Anti-Torque A type	
RG.IN.0008	Anti-Torque C type	
RG.IN.0018	Sleeve Cutter	

**DioMedical (U.S.)**

8770 W. Bryn Mawr Ave. Suite 1250,  
Chicago, IL 60631, United States

Tel: +1-847-795-1047

Fax: +1-847-795-1079

Email: [info@dio-us.com](mailto:info@dio-us.com)

[www.diomedicalus.com](http://www.diomedicalus.com)

