

Hana™

Anterior Cervical Uniplate System

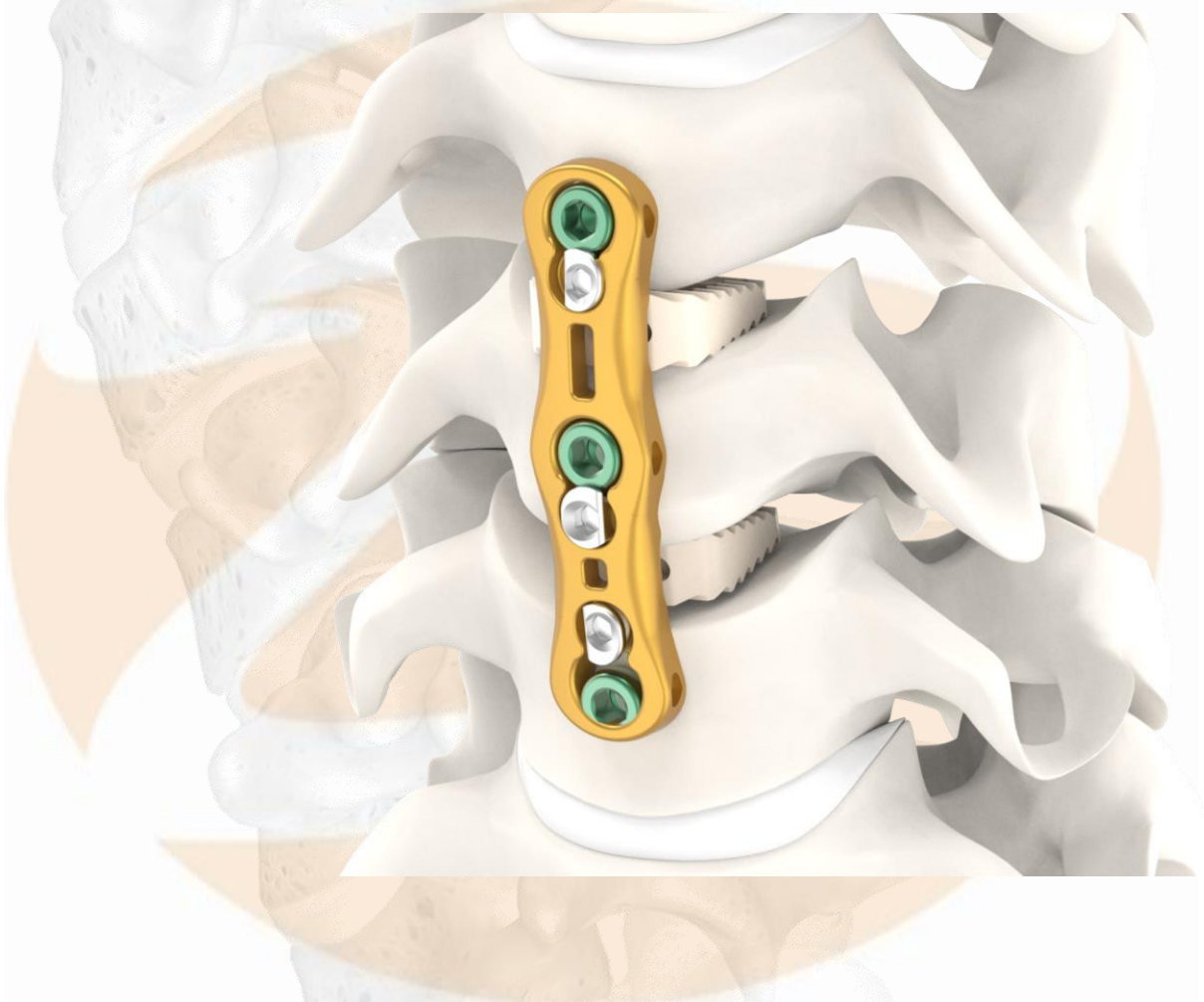

CONTENTS

IMPLANT OVERVIEW

- Implant overview Page 1

SURGICAL TECHNIQUE

- STEP 1: Patient positioning and exposure Page 2
- STEP 2: Approach and cage placement Page 2
- STEP 3: Plate placement Page 2
 - Plate Bender Instruction Page 3
- STEP 4: Screw hole preparation Page 4
- STEP 5: Screw insertion Page 5
- STEP 6: Locking Page 5
- STEP 7: Locking/Unlocking with 2.1 hex driver (Optional) Page 6
- STEP 8: Closure and postoperative care Page 6
- STEP 9: Removal (Optional) Page 6

INSTRUMENT LIST

- Surgical set overview Page 7
- Surgical set images Page 8

Images may not look the same as the actual product.

This surgical tech guide alone may not offer all information, or knowledge, required to perform spinal surgery, thus additional instruction, or performance, of an experienced surgeon is recommended.

IMPLANT OVERVIEW

FEATURES & BENEFITS

- Visual and tactile confirmation of screw blocking
- Spikes on the bottom of the plate to strengthen in rotational stability
- Streamlined instrumentation for reduced implantation steps
- Color coded on screws for easy identification

PLATE

- 1-2 levels
- Thickness: 2.3 mm
- Width: 10 mm (Waist: 8.5 mm)
- Length (hole to hole)
 - 13-25 mm (1 level, 2 mm increments)
 - 26-46 mm (2 level, 2 mm increments)
- Titanium alloy (Ti-6Al-4V ELI)
- Provides up to 17° of cephalad angulation

SCREW

- Size: 4.6 mm, 5.1 mm
- Length: 12-20 mm (2mm increments)
- Titanium alloy (Ti-6Al-4V ELI)
- Self-drilling and self-tapping
- Variable and fixed angle screws
- Color coded for easy identification



1 Level Plate – Sagittal view



SURGICAL TECHNIQUE

STEP 1: PATIENT POSITIONING and EXPOSURE

The patient is carefully placed in the supine position on the operating table following the induction of anesthesia. The head is placed in a neutral position. A transverse or oblique skin incision is made, and the incision site is held open by a longitudinal self-retaining retractor.

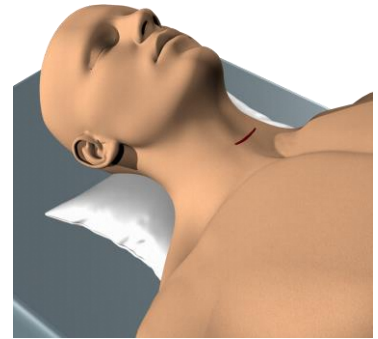

STEP 2: APPROACH and CAGE PLACEMENT

Expose the appropriate cervical levels for surgical treatment. The distraction pins are positioned midline in the vertebral bodies adjacent to the disc, and the distractor is placed over pins. Distract gently. Refer to the IVA ACIF Surgical Technique Guide for recommended techniques for cage insertion. The surface of the vertebral body may require some preparation by removing anterior osteophytes for flush bone-plate interface.

STEP 3: PLATE PLACEMENT

HANA is available in 1 level and 2 levels. Select the appropriate plate size. Plate width is 10mm and the waist is 8.5mm. Plate length is measured from the center of the cephalad hole to the center of the caudal hole, ranging from 13 to 25mm for 1 level procedure and 26 to 46mm for 2 level procedure. Additional contouring may be accomplished by using the plate bender to accommodate patient pathology.

Place the plate on the vertebral column by using the Plate Holder. The DTS Guide may be used to place the plate, alternatively.

Note: HANA system has bend zones from 19mm and larger 1 level plates and 36mm and larger 2 level plates

Note: Do not bend on the locking plate. Bending on the locking plate will compromise the locking plate ability to lock the screw

Note : Add 8mm for total plate length

SURGICAL TECHNIQUE

PLATE BENDER - INSTRUCTION

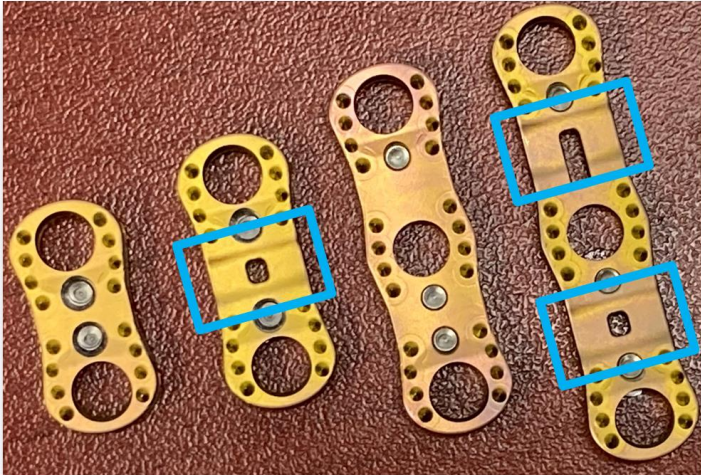

Available bending zone (Blue box)

1 level
17 – 25 mm

2 level
34 – 46 mm, half part of 28, 30, 32 mm

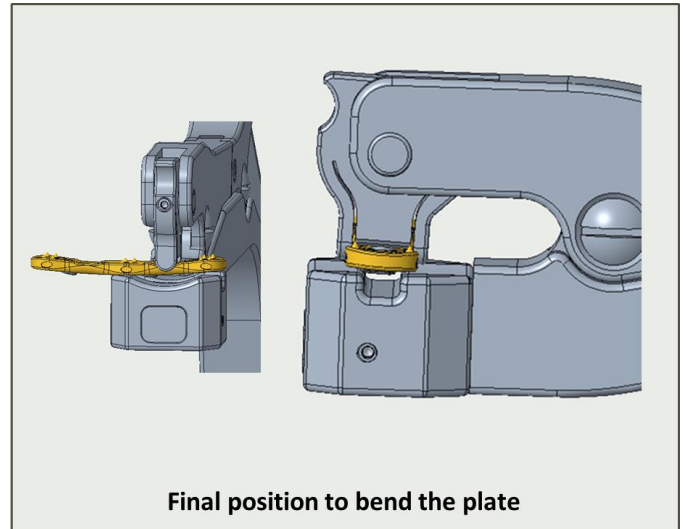
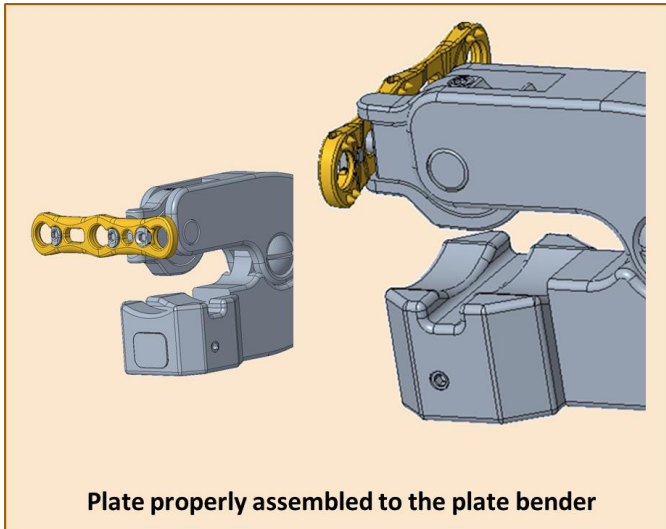

Note: Please contact Dio Medical to request further inquiry.

STEP 4: BONE SCREW HOLE PREPARATION

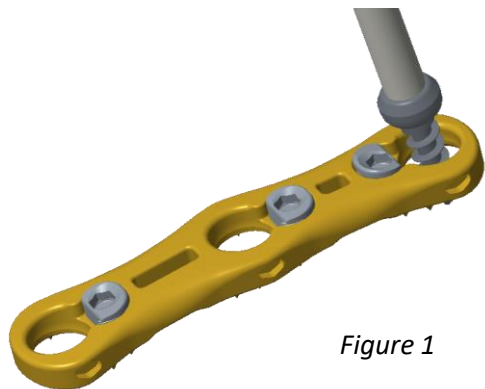

Figure 1

The Temporary Fixation Pin can be used to secure the plate, temporarily. The Temporary Fixation Pin can be used with the Screwdriver, 2.5mm hex. The Temporary Fixation Pin hole may be used as pilot hole for the screw (Figure 1).

Use either the Awl With Sleeve (variable angulation) or the Awl For Drill Guide (fixed or variable angulation) for the entry points or initial pilot hole (Figure 2). The Awl For Drill Guide can be used with either the DTS Guide (fixed angle) or the Drill Guide (fixed or variable angle, Figure 3). The Awl With Sleeve protrudes into the bone a maximum of 9mm.

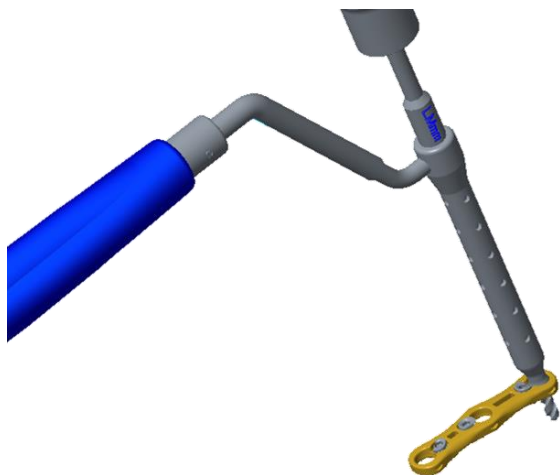

Figure 2

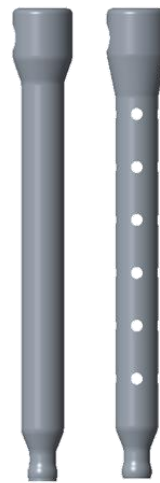

Figure 3

Left: Fixed Drill Guide
Right: Variable Drill Guide

The Drill Bit length can be distinguished by the laser marking towards the proximal end (Figure 4). To maximize purchase, the Cervical Tap may be used with the DTS guides.



Figure 4

STEP 5: SCREW INSERTION

After selecting the desired screw type and size, remove the screw from the screw caddy using 2.5mm hex self-retaining Screwdriver (Figure 5). If a 2 level plate is being used, it is recommended that bone screws be placed at the intermediate levels first. Use fluoroscopic imaging to confirm the final trajectory of the screw and plate position before bone screws are fully tightened.

Note: Avoid insertion angulation of the screws greater than 17 to ensure optimal locking of the screw to the plate.

Note: All screw lengths are measured by bone engagement, not overall length

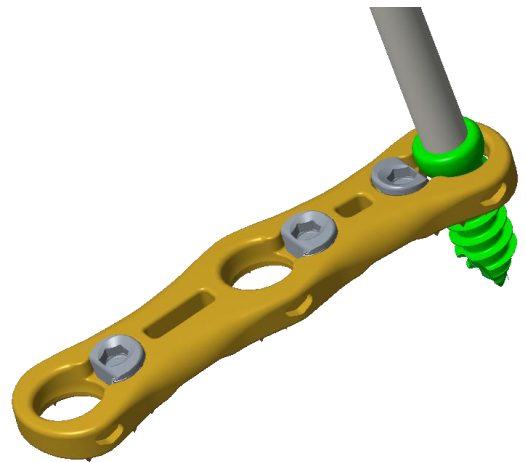

Figure 5

STEP 6: LOCKING

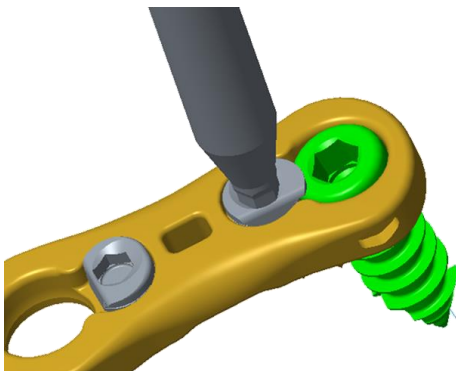
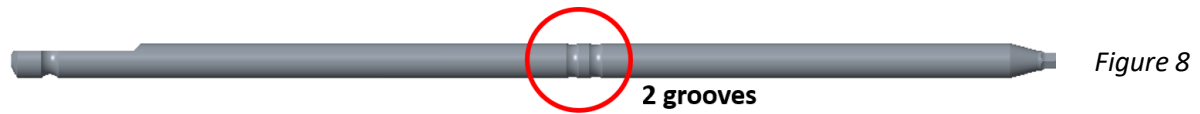
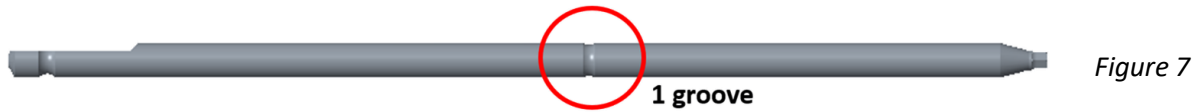

Figure 6

Once the bone screws are fully tightened, lock the lock-plate by turning clockwise 90° using the 2.0mm Hex Lock-plate driver (Figure 6). The lock plate will stop after you turn the lock-plate 90°. The locking step will provide tactile and visual confirmation. Confirm the final position of the implant under fluoroscopy imaging.

STEP 6-1: LOCKING/UNLOCKING with 2.1 HEX DRIVER (OPTIONAL)

When the lock plate hex is stripped, the Lock Driver, 2.1m Hex, QC (Figure 8) can be used as a rescue driver to either unlock or lock the lock plate instead of standard Lock Driver, 2.0 Hex (Figure 7).



STEP 8: CLOSURE and POSTOPERATIVE CARE

Following are few of the recommended steps:

- The operative site should be closed per hospital protocol and the surgeon's discretion. Prior to adequate fusion, the physician may prescribe additional external support (e.g. braces) to accommodate full load bearing
- Routine monitoring of the vital signs, and of the hemodynamic and neurologic status of the patient per hospital protocol and the surgeon's discretion
- Pain Medication per hospital protocol and the surgeon's discretion
- Diet is restricted to small amounts of liquids until return of bowel function per hospital protocol and the surgeon's discretion
- The patient is encouraged to ambulate as soon as possible based on the activity level determined by the individual surgeon.

STEP 9: REMOVAL (OPTIONAL)

The insertion instruments can be used to engage the implant securely in-situ. The implant can then be extracted by following the implantation process in the reverse order. Optionally, forceps or other manual surgical instruments may be used to grasp and extract the implant. If necessary, distract the vertebrae inferior and superior to the implant for removal.

SURGICAL SET OVERVIEW

Plate

1-2 level

| Part No. | Set Quantity |
|------------|--------------|
| UP.PL.0113 | 2 |
| UP.PL.0115 | 2 |
| UP.PL.0117 | 2 |
| UP.PL.0119 | 2 |
| UP.PL.0121 | 2 |
| UP.PL.0123 | 2 |
| UP.PL.0226 | 2 |
| UP.PL.0228 | 2 |
| UP.PL.0230 | 2 |
| UP.PL.0232 | 2 |
| UP.PL.0234 | 2 |
| UP.PL.0236 | 2 |

Screw

Variable-angle (self-drilling), Ø4.6 and 5.1

| Part No. | Set Quantity |
|------------|--------------|
| UP.VD.4612 | 6 |
| UP.VD.4614 | 6 |
| UP.VD.4616 | 6 |
| UP.VD.5112 | 6 |
| UP.VD.5114 | 6 |
| UP.VD.5116 | 6 |

Instrument

Standard Configuration

| Part No. | Set Quantity |
|--|--------------|
| Screwdriver, Self-Retaining | 2 |
| Lock driver, 2.0 Hex | 1 |
| Lock driver, 2.1 Hex (rescue driver) | 1 |
| Plate Holder | 1 |
| Plate Bender | 1 |
| Variable angle Drill Guide (single barrel) | 1 |
| Drill bit - 12 mm | 1 |
| Drill bit - 14 mm | 1 |
| Drill bit - 16 mm | 1 |
| A-O Quick Connect Handle, Swivel | 2 |
| Cervical Awl, for Drill Guide | 1 |
| Temporary Fixation pin | 4 |
| Implant Caddy Case | 1 |
| Screw Caddy Case (SD) | 1 |
| AL Case | 1 |

Additionally Available

| Description |
|---|
| UP.PL.0125 |
| UP.PL.0238 |
| UP.PL.0240 |
| UP.PL.0242 |
| UP.PL.0244 |
| UP.PL.0246 |
| UP.VD.4618 |
| UP.VD.4620 |
| UP.VD.5118 |
| UP.VD.5120 |
| Fixed drilling screws |
| Pre-set angle Drill Guide (single barrel) |
| Cervical Awl, with Sleeve |

Note: Additionally available instruments should be requested in advance and please contact Dio Medical to confirm the set configurations which may vary depending on locations.

SURGICAL SET IMAGE

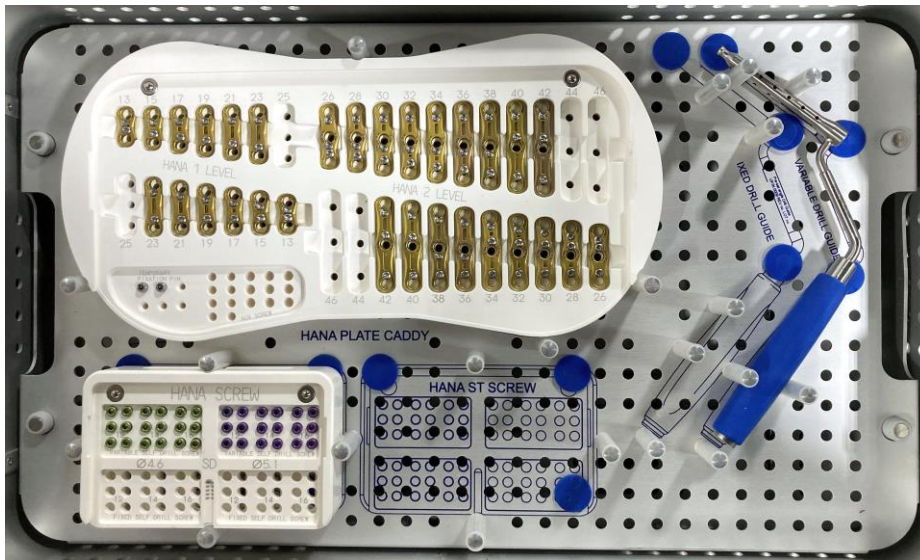

Tray, Top



Tray, Bottom

INDICATION and CONTRAINDICATIONS

Indications

The FORTIS and HANA Anterior Cervical Plate System is intended for anterior fixation to the cervical spine C2-C7. The specific clinical indications include: degenerative disc disease (DDD) (defined as neck pain of discogenic origin with degeneration of the disc confirmed by history and radiographic studies), spondylolisthesis, trauma (i.e., fracture or dislocation), spinal stenosis, deformities or curvatures (i.e., scoliosis, kyphosis, and/or lordosis), tumor, pseudoarthrosis, and failed previous fusion.

Contraindications

Contraindications may be relative or absolute. The choice of a particular device must be carefully weighed against the patient's overall evaluation. Circumstances listed below may reduce the chances of a successful outcome:

- Patients with probable intolerance to the materials used in the manufacture of this device.
- Patients with infection, inflammation, fever, tumors, elevated white blood count, obesity, pregnancy, mental illness and other medical conditions which would prohibit beneficial surgical outcome.
- Patients resistant to following post-operative restrictions on movement, especially in athletic and occupational activities.
- Use with components from other systems
- Grossly distorted anatomy caused by congenital abnormalities.
- Any other medical or surgical condition which would preclude the potential benefit of spinal implant surgery.
- Rapid joint disease, bone absorption, osteopenia. Osteoporosis is a relative contraindication since this condition may limit the degree of obtainable correction, stabilization, and/or the amount of mechanical fixation.
- Any case where the implant components selected for use would be too large or too small to achieve a successful result.
- Any patient having inadequate tissue coverage over the operative site or inadequate bone stock or quality.
- Any patient in which implant utilization would interfere with anatomical structures or expected physiological performance.
- Any case not described in the indications for use.
- Reuse or multiple uses.
- Prior fusion at the level(s) to be treated.
- metals from different components;

These contra-indications can be relative or absolute and must be taken into account by the physician when making his decision. The above list is not exhaustive. Surgeons must discuss the relative contraindications with the patients.

Caution

- Instruments designed for use with implantation of the FORTIS and HANA Anterior Cervical Plate System are provided non-sterile and must be sterilized prior to use.
- Based on the fatigue testing results, the physician/surgeon must consider the levels of implantation, patient weight, patient activity level, other patient conditions, etc. Which may impact the performance of the FORTIS and HANA Anterior Cervical Plate System.
- The implantation of the FORTIS and HANA Anterior Cervical Plate System must be performed only by experienced spinal surgeons with specific training in the use of this device because this is a technically demanding procedure presenting a risk of serious injury to the patient.
- Potential risks identified with the use of this FORTIS and HANA Anterior Cervical Plate System, which may require additional surgery, include: device component fracture, loss of fixation, pseudoarthrosis (i.e. non-union), fracture of the vertebrae, neurological injury, and vascular or visceral injury.
- Patients with previous spinal surgery at the level(s) to be treated may have different clinical outcomes compared to those without a previous surgery.
- The components of the system should not be used with components of any other system or manufacturer. Any such use will negate the responsibility of HUVEXEL for the performance of the resulting mixed component implant. Federal law restricts this device to sale by or on the order of a physician/surgeon (Rx only).

Pre-Operative Precautions

The surgical indication and the choice of implants must take into account certain important criteria such as:

- Patients involved in an occupation or activity that applies excessive loading upon the implant (e.g., substantial walking, running, lifting, or muscle strain) may be at increased risk for failure of the fusion and/or the device.
- Surgeons must instruct patients in detail about the limitations of the implants, including, but not limited to, the impact of excessive loading through patient weight or activity, and be taught to govern their activities accordingly. The procedure will not restore function to the level expected with a normal, healthy spine, and the patient should not have unrealistic functional expectations.
- A condition of senility, mental illness, chemical dependence or alcoholism. These conditions among others may cause the patients to ignore certain necessary limitations and precautions in the use of the implant, leading to failure and other complications.

INDICATION and CONTRAINDICATIONS

- Foreign body sensitivity. Where material sensitivity is suspected appropriate tests should be made prior to material implantation.
- Surgeons must advise patients who smoke have been shown to have an increased incidence of non-unions. Such patients must be advised of this fact and warned of the potential consequences.
- Care must be taken to protect the components from being marred, nicked, or notched as a result of contact with metal or abrasive objects.

Intra-Operative Precautions

- The insertion of the implants must be carried out using instruments designed and provided for this purpose and in accordance with the specific implantation instructions for each implant. Those detailed instructions are provided in the surgical technique brochure supplied by Huvexel.
- Discard all damaged or mishandled implants.
- Never reuse an implant, even though it may appear undamaged.

Adverse Effects

Include but are not limited to:

- Early or late loosening of any or all of the components.
- Disassembly, bending, and/or breakage of any or all of the components. Late bone fusion or no visible fusion mass and pseudarthrosis;
- While the expected life of spinal implant components is difficult to estimate, it is finite. These components are made of foreign materials which are placed within the body for the potential fusion of the spine and reduction of pain. However, due to the many biological, mechanical and physicochemical factors which affect these devices but cannot be evaluated in vivo, the components cannot be expected to indefinitely withstand the activity level and loads of normal healthy bone;
- Superficial or deep-set infection and inflammatory phenomena;
- Allergic reactions to the implanted materials, although uncommon, can occur;
- Decrease in bone density due to stress shielding;
- Peripheral neuropathies, nerve damage, heterotopic bone formation and neurovascular compromise, including paralysis, loss of bowel or bladder function, or foot-drop may occur.
- Cessation of growth of the fused portion of the spine;
- Loss of proper spinal curvature, correction, height and/or reduction;
- Delayed Union or Nonunion: Internal fixation appliances are load sharing devices which are used to obtain alignment until normal healing occurs.
- In the event that healing is delayed, does not occur, or failure to immobilize the delayed/nonunion results, the implant will be

subject to excessive and repeated stresses which can eventually cause loosening, bending or fatigue fracture. The degree or success of union, loads produced by weight bearing, and activity levels will, among other conditions, dictate the longevity of the implant. If a nonunion develops or if the implants loosen, bend or break, the device(s) must be revised or removed immediately before serious injury occurs;

Neurological from surgical trauma;

Early loosening may result from inadequate initial fixation, latent infection, premature loading of the device or trauma. Late loosening may result from trauma, infection, biological complications or mechanical problems, with the subsequent possibility of bone erosion, or pain. Serious complications may occur with any spinal surgery. These complications include, but are not limited to, disorders; vascular disorders, including thrombus; bronchopulmonary disorders, including emboli; bursitis, hemorrhage, myocardial infarction, infection, paralysis or death. Inappropriate or improper surgical placement of this device may cause distraction or stress shielding of the graft or fusion mass. This may contribute to failure of an adequate fusion mass to form. Intraoperative fissure, fracture, or perforation of the spine can occur due to implantation of the components. Postoperative fracture of autograft and/or allogeneic bone graft comprised of cancellous and/or corticocancellous bone graft or the intervertebral body above or below the level of surgery can occur due to trauma, the presence of defects, or poor bone stock. Adverse effects may necessitate reoperation or revision.

The surgeon must warn the patient of these adverse effects as deemed necessary.

Indications

The FORTIS and HANA Anterior Cervical Plate System is intended for anterior fixation to the cervical spine C2-C7. The specific clinical indications include: degenerative disc disease (DDD) (defined as neck pain of discogenic origin with degeneration of the disc confirmed by history and radiographic studies), spondylolisthesis, trauma (i.e., fracture or dislocation), spinal stenosis, deformities or curvatures (i.e., scoliosis, kyphosis, and/or lordosis), tumor, pseudoarthrosis, and failed previous fusion.

DIO MEDICAL CORP.
2100 Campus Lane, East Norriton, PA 19403
1-877-394-5407
info@dio-us.com
www.dio-us.com

